



Export map

Experience Since 1998 y.
Manufacturing of Oil/Water separators Grease separators Pumping Stations Waste Water Treatment Plants

Certificates
ISO 9001
ISO 14001
ISO 45001
SINTEF
SINGAPORE GREEN BUILDING PRODUCT 'VERY GOOD'

Services
Custom Rotational Molding Design and Manufacturing of unique plastic products

UAB ENEKA
Vandžiogalos pl. 94D, LT-47467, Kaunas, Lithuania
Phone.: +370 37 377441
E-mail: info@eneka.lt
www.eneka.lt



FREE-STANDING AND UNDERGROUND MODELS



Free standing Grease Separators

For installation inside buildings

Greasly-A is a new grease separator model made of polyethylene for free-standing installation inside buildings. Greasly-A are compact, rigid and lightweight but very rigid units at the same time. All separators are equipped with integrated sludge trap. Currently, there are two nominal sizes of above-ground separators available for a flow rates from 2 to 20 l/s. The other nominal sizes on request.

Easy selection of flow direction

Due to symmetrical design of separator the flow direction can be selected according to existing pipeline layout. Inlet or outlet pipe can be connected on the right or left side of separator.

Refilling unit

After disposal the separator shall be refilled by fresh water without opening of the lid and thus ensuring odour-free filling.

Fits through any door

A tight grease separator body (width is only 700 mm of NS2 and NS4) can easily fit through any standard door. Thus Greasly-A is a good choice for installation in spaces with narrow access.



Fits through any door

Extraction pipe

for complete emptying of separator without opening of the cover.

Inspection window with wiper

for visual control of grease layer.

Complete emptying of the tank

Bottom of the separator is inclined towards the center. Extraction pipe is connected at the lowest point ensuring complete emptying of accumulated grease and solids from the lowest point.

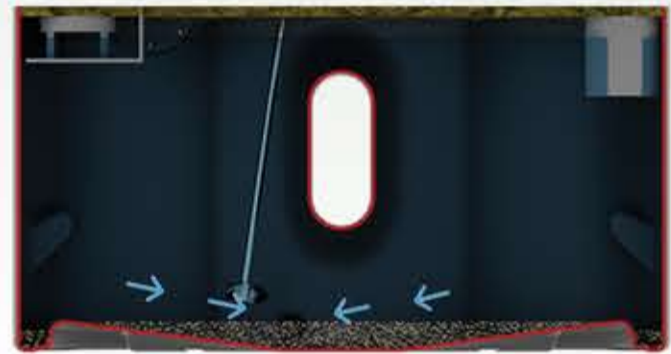

Sloped bottom

No bad odour

Access covers are tightened by locking rings with gasket ensuring odour-free operation. There is no need to open cover during the maintenance since accumulated grease and sludge can be disposed through extraction pipe or by means of disposal pump.



Cover locking ring with a gasket

Convenient allocation in the room

The grease separator is maintained from one side therefore it can be set up next to the wall. The accessories (inspection window, Extraction pipe, Disposal pump) can be attached from both sides.



Greasly-A next to the wall

Mixer

Before disposal, accumulated grease and sludge are blended with water to facilitate emptying of the separator.



Mixer

Rigid and durable design

Advanced design of separator's body ensures great stiffness and perfect resistance against internal water pressure and higher temperatures.

Models

Greasly-A

Following main components are included in every Greasly-A model:

Separator tank with two airtight covers ø400 mm with seals and metallic locking rings, integrated sludge trap, sloped bottom for complete discharge, special inlet nozzle and outlet nozzle for efficient grease separation.



Model BASE

Model BASE

BASE model can be applied in areas where bad odour during the maintenance is not causing any inconvenience. Access cover shall be opened for disposal of accumulated grease and solids by vacuum truck.



Model PRIMA

Model PRIMA

Manual disposal system type 1 including: Inspection window, Extraction pipe, Refilling unit. PRIMA model provides odour-free operation without the need for opening of the cover. Accumulated grease and sludge are disposed through Extraction pipe by vacuum truck, after complete disposal, separator is filled-up with fresh water through Refilling unit.



Model MIX

Model MIX

Manual disposal system type 2 including: Grease alarm Inspection window, Extraction pipe, Mixer with manual controller, Refilling unit. MIX model is equipped with Grease alarm indicating when maximum level of accumulated grease is reached. Before emptying, Mixer actuated for blending grease, water and solid layers thus facilitating emptying of the separator. A special Extraction pipe is provided for emptying of grease separator by the vacuum truck, after complete disposal the separator is filled-up with fresh water.



Model PUMP

Model PUMP

Automatic disposal system including: Grease alarm Inspection window, Extraction pipe, refilling unit, Mixer with manual controller, refilling unit. PUMP model is equipped with autonomous automatic emptying system including Disposal pump. When the maximum level of accumulated grease is reached, Grease alarm activates the automatic disposal mode. First of all, the mixer is turned on for blending grease, water and solid layers. Then the Disposal pump is actuated for emptying rinsed by fresh water which filled through refilling unit, mixed and emptied by the Disposal pump, after rinsing, the separator is filled-up with fresh water again.

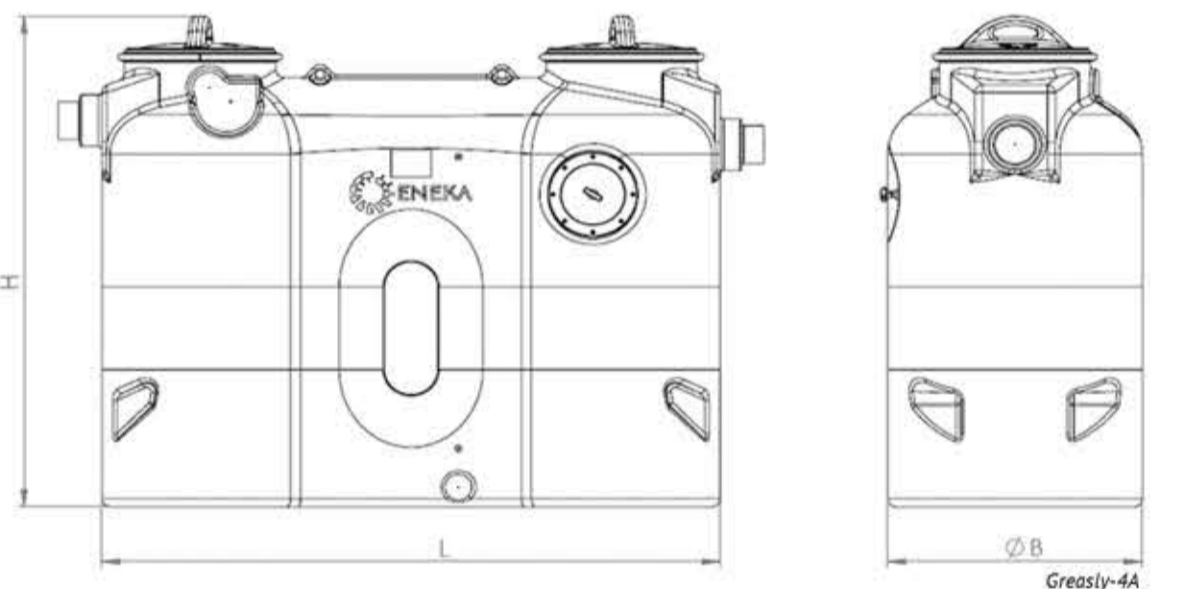

Greasly-4A

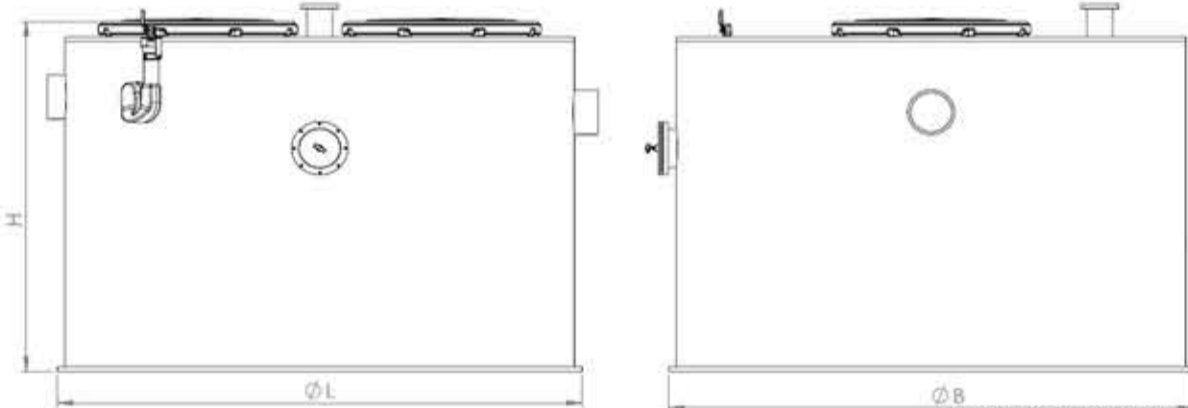

Greasly-7A...204 dimensions

Greasly-A technical data

Type	Article No.	Flow rate, l/s	Sludge trap volume, l	Separator volume, l	Grease volume, l	Total volume, l	Weight, kg	Dimensions, mm		
								L	H	B
Greasly-2A	1201-A002	2	200	250	80	650	78-144	1940	1190	700
Greasly-4A	1201-A004	4	400	450	160	850	91-157	1940	1430	700
Greasly-7A	1201-A007	7	700	1180	280	1880	232	1300	2182	1300
Greasly-10A	1201-A010	10	1000	1610	400	2610	355	1840	1909	1840
Greasly-15A	1201-A015	15	1500	1798	600	3298	417	2240	1580	2240
Greasly-20A	1201-A020	20	2000	2200	800	4200	507	2240	1942	2240

Table No.1

Accessories



Underground grease separators Greasly-B

Greasly - a part of modern kitchen

Typical application of a grease separator is treatment of wastewater containing fat and grease from hotels, restaurants, cafeterias and other catering or food processing operations. GREASLY will, by the removal of fat and grease, greatly reduce incidents of blocked drains and prevent contamination of sewage treatment plants.

ENEKA offers above ground Greasly-A and underground Greasly-B grease separator models. Greasly separators were developed to comply with EN 1825 and DIN4040-100 standards. Rotomoulded tanks made of polyethylene material are durable, corrosion-proof and chemically resistant, light and easy to transport.



Operating principle

Simple maintenance

Greasly requires only little service which is limited by removal of accumulated grease and sludge by vacuum truck. After disposal, internal surfaces of the separator shall be cleaned by high-pressure cleaner. Smooth surfaces of rotomoulded polyethylene tanks are ensuring simple and efficient cleaning.

Telescopic maintenance shaft

for adjustment of the lid flush with the ground surface (adjustment range 200 mm).

Easy installation

The solid and light structure allows Greasly-B to be installed deep in the ground without any concrete reinforcements.

Integrated ladder provides easy and safe access into the tank.

Extraction pipe

for connection of extraction hose of vacuum truck. Article No. 1202-2200.

Rigid body
Great stiffness of the separator body against ground and groundwater loads is achieved due to the advanced design and special ribbed structure. Greasly-B is manufactured of polyethylene material which is leak and corrosion-proof.

Spray nozzle

As an option, a special spray nozzle can be installed into a tank for cleaning of internal surfaces and refilling with fresh water without opening of the cover, which ensures odour free operation. Article No. 1202-2100.

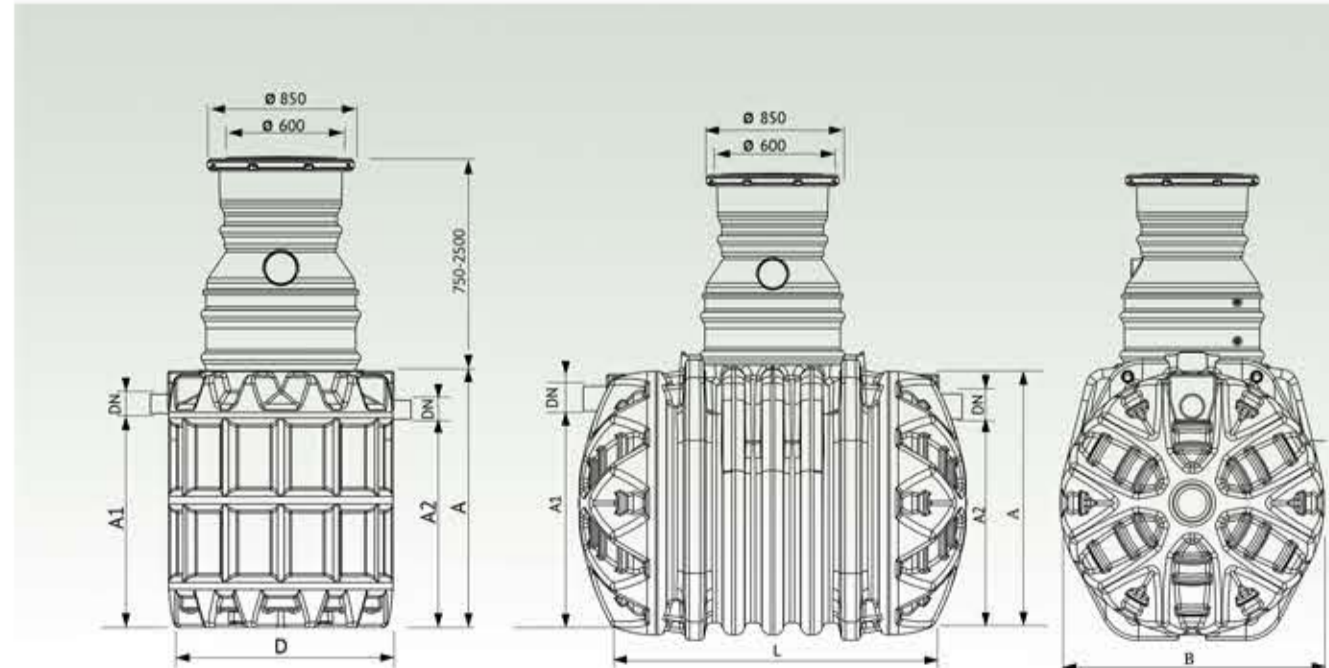

Greasly-B technical data

Type	Article No.	Flow rate, l/s	Sludge trap volume, l	Separator volume, l	Grease volume, l	Total volume, l	Dimensions mm						
							D/L*	A	B	A1	A2	DN	
Greasly-1B	1202-01	1	100	250	40	350	925	1100	925	755	685	110	85/110
Greasly-2B	1202-02	2	200	550	80	750	1300	1000	1300	740	670	110	96/130
Greasly-4B	1202-04	4	400	850	160	1250	1900	1490	1300	1240	1170	110	96/146
Greasly-7B	1202-07	7	700	1700	280	2400	2400	1515	1450	1170	1100	160	166/255
Greasly-10B	1202-10	10	1000	1400	400	2400	2400	1515	1450	1170	1000	160	166/255
Greasly-15	1202-15	15	1560	3970	750	5530	3500	1830	1690	1450	1380	200	305/415
Greasly-20	1202-20	20	2140	4930	1000	7070	4500	1830	1690	1450	1380	200	376/535
Greasly-25	1202-25	25	2500	5720	1250	8220	5000	1830	1690	1450	1380	200	475/600

Table No.2

* L - for horizontal and D - vertical models.
** S - Standard corps for installation in depth of A1 < 1500 mm, R - reinforced corps for installation in depth of A1 < 2500 mm.

Optimal grease separation

The operating principle of Above ground and underground grease separators is the same. Incoming greasy wastewater enters the grease separator through unique inlet module which creates the circular flow path. As water passes through the separator, grease particles, lighter than water, are driven upwards by gravity and accumulated in the collection area on the water surface. At the same time, solids and other impurities heavier than water settle to sludge trap at the bottom of the tank. Treated water is discharged through outlet pipe.

Approvals

Greasly is ensuring the residual grease content less than 25 mg/l in the effluent wastewater. Performance of separators was practically tested (at Danish Technological Institute and Kaunas University of Technology). The conformity to European standard EN 1825 is signified by the CE mark.



Greasly-B horizontal model